

Resilient-Seated Gate Valves with Vertical or Cross Wall Post Indicator

General Description

TYCO Resilient-Seated Gate Valves with Vertical and Cross Wall Indicators are used in fire protection systems for on/off operation. End connection configurations including Flange by Flange, Flange by Groove, and Groove by Groove are available.

The ductile iron body weighs approximately 50% less than conventional cast iron valves, which allows easier handling on site and reduced shipping costs.

The fully encapsulated EPDM ductile iron wedge ensures drop-tight sealing.

Valve components are either inherently corrosion-resistant or protected with fusion-bonded epoxy resin coating for a long, reliable service life and enhanced UV protection in exposed installations.

This valve is one of the lightest, most durable gate valves on the market today. Its design features and material selection criteria fulfill the need for a reliable, long life and easy to operate gate valve.

These valves are available with either Vertical Indicators for underground water supplies or Cross Wall Indicators for interior water systems. Both indicators provide external visual indication of the open or shut valve condition as well as a locking mechanism to secure a particular wedge position.

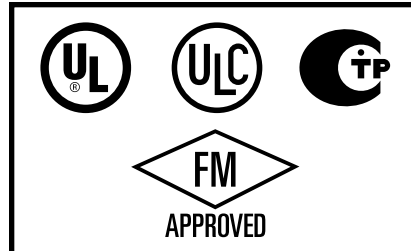

NOTICE

Never remove any piping component nor correct or modify any piping deficiencies without first de-pressurizing and draining the system. Failure to do so may result in serious personal injury, property damage, and/or impaired device performance.

It is the designer's responsibility to select products suitable for the intended service and to ensure that pressure ratings and performance data are not exceeded. Material and gasket selection should be verified for compatibility with the specific application. Always read and understand the installation instructions.

TYCO Gate Valves described herein must be installed and maintained in compliance with this document, in addition to the standards of any other authorities having jurisdiction. Failure to do so may result in serious personal injury or impair the performance of these devices.

The owner is responsible for maintaining their mechanical system and devices in proper operating condition. The installing contractor or device manufacturer should be contacted with any questions.

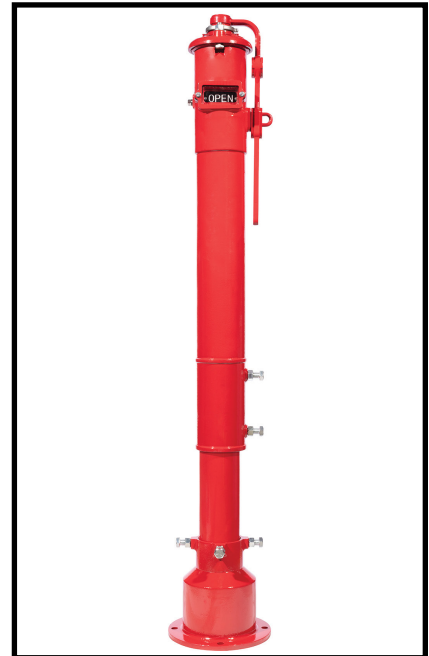

IMPORTANT

Refer to Technical Data Sheet TFP2300 for warnings pertaining to regulatory and health information.

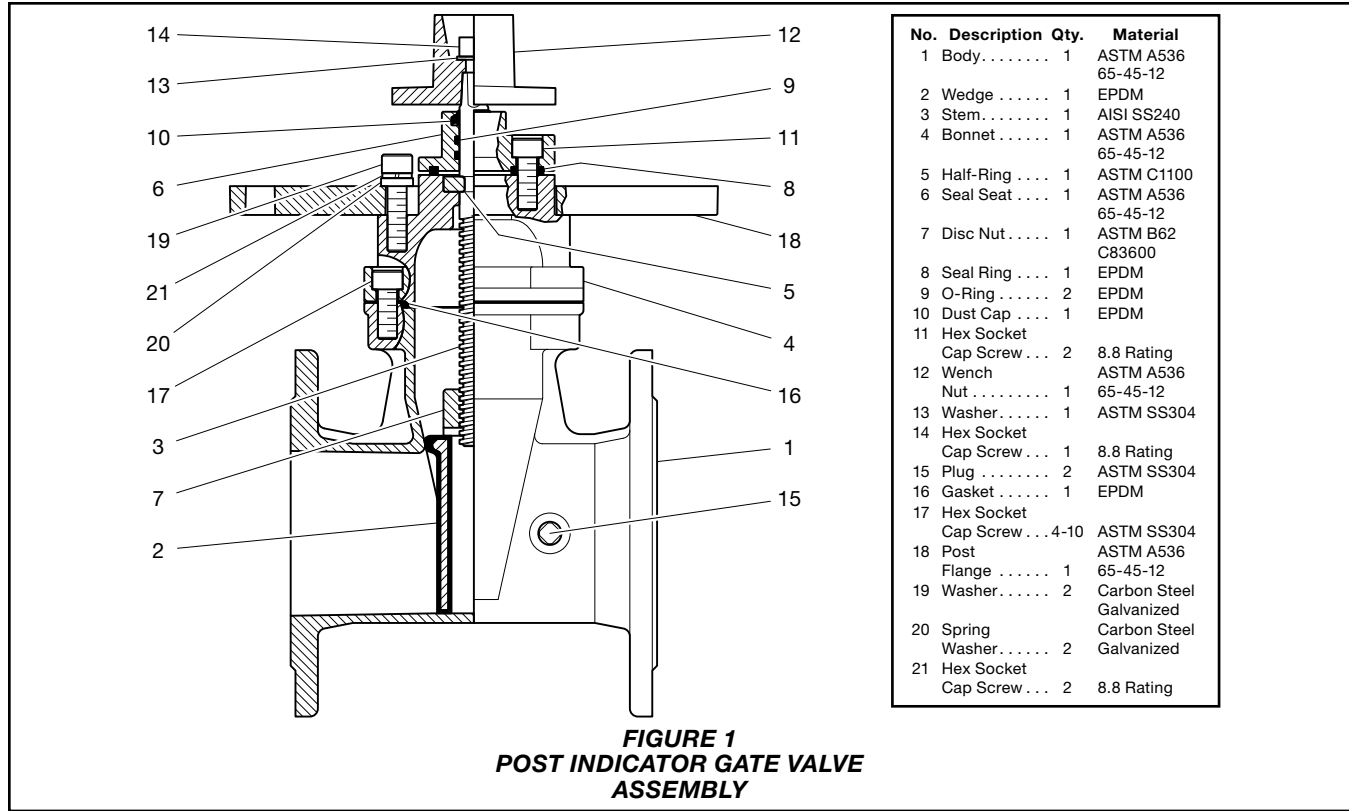

FIGURE 1
POST INDICATOR GATE VALVE
ASSEMBLY

Nominal Valve Size	Nominal Dimensions in Inches (mm)								
	ANSI Class 150			ISO 7005-2 PN16			AS 2129 (Table E)		
	Dim. A	Dim. B	Qty. N	Dim. A	Dim. B	Qty. N	Dim. A	Dim. B	Qty. N
2 DN50	4.75 (120.7)	0.75 (19.0)	4	4.92 (125.0)	0.75 (19.0)	4	4.49 (114.0)	0.71 (18.0)	4
4 DN100	7.50 (190.5)	0.75 (19)	8	7.09 (180.0)	0.75 (19)	8	7.00 (178.0)	0.71 (18.0)	8
6 DN150	9.50 (241.5)	0.88 (22)	8	9.45 (240.0)	0.88 (23)	8	9.25 (235.0)	0.87 (22.0)	8
8 DN200	11.75 (298.5)	0.88 (22)	8	11.61 (295.0)	0.88 (23)	12	11.49 (292.0)	0.87 (22.0)	8
10 DN250	14.25 (362.0)	1.00 (25)	12	13.98 (355.0)	1.13 (28)	12	14.02 (356.0)	0.87 (22.0)	12
12 DN300	17.00 (432.0)	1.00 (25)	12	16.14 (410.0)	1.13 (28)	12	15.98 (406.0)	1.02 (26.0)	12
14 DN350	18.75 (476.3)	1.13 (28.6)	12	18.5 (470.0)	1.102 (28)	16	18.50 (470.0)	1.02 (26.0)	12
16 DN400	21.25 (539.8)	1.13 (28.6)	16	20.67 (525.0)	1.22 (31)	12	20.51 (521.0)	1.02 (26.0)	12
18 DN450	22.75 (577.9)	1.26 (32.0)	16	23.03 (585.0)	1.22 (31)	20	19.84 (504.0)	1.02 (26.0)	12
20 DN500	25.00 (635.0)	1.26 (32.0)	20	25.59 (650.0)	1.34 (34)	20	25.24 (641.0)	1.02 (26.0)	16
24 DN600	29.51 (749.5)	1.378 (35.0)	20	30.31 (770.0)	1.46 (37)	20	29.76 (756.0)	1.30 (33.0)	16

Dim. A
Bolt Circle Diameter

Dim. B
Bolt Hole Diameter

Qty. N
Number of Bolt Holes

NOTES

- ANSI 150 and BS10 Table E flanges feature raised faces
- ANSI 125 and PN16 flanges feature flat faces (ANSI 125 listed only for differentiation from ANSI 150, Gate Valves featuring ANSI 125 flanges are not available)

TABLE A
GATE VALVE SELECTION FLANGE DRILLING SPECIFICATIONS

Nominal Valve Size	Nominal Pipe Size	Nominal Dimensions in. (mm)		P Tapping Boss Size ANSI in. NPT	Approx. Weight F x F lb (kg)	Approx. Weight F x G lb (kg)	Approx. Weight G x G lb (kg)
		L	CL				
2 DN50	2.375 (60.3)	7.00 (178)	10.98 (279)	1/2	25.0 (11.34)	24.1 (10.92)	23.11 (10.49)
4 DN100	4.500 (114.3)	9.00 (229)	13.07 (332)		77.0 (35)	73.5 (33.4)	50.8 (23.1)
- DN150	6.500 (165.1)	10.50 (267)	17.17 (436)		110.0 (50)	105.7 (48)	101.4 (46.1)
6 DN150	6.625 (168.3)	10.50 (267)	17.17 (436)		110.0 (50)	105.7 (48)	101.4 (46.1)
8 DN200	8.625 (219.1)	11.50 (292)	20.47 (520)	3/4	182.6 (83)	184.8 (84)	187 (85)
10 DN250	10.750 (273.1)	13.00 (330)	24.41 (620)	1	271.7 (123.5)	266.2 (121)	260.7 (118.5)
12 DN300	12.750 (323.9)	14.00 (356)	26.38 (670)		386.1 (175.5)	378.4 (172)	370.7 (168.5)
14 DN350	14.000 (355.6)	15.00 (381.0)	33.94 (862)		506.0 (230)	-	-
16 DN400	16.000 (406.4)	15.98 (406.0)	36.93 (938)		712.8 (324)	-	-
18 DN450	18.000 (457.2)	17.00 (432.0)	41.61 (1057)		968 (440)	-	-
20 DN500	20.000 (508.0)	17.99 (457.0)	44.96 (1142)		1403.6 (638)	-	-
24 DN600	24.000 (609.6)	20.0 (508.0)	50.98 (1295)		1804 (820)	-	-

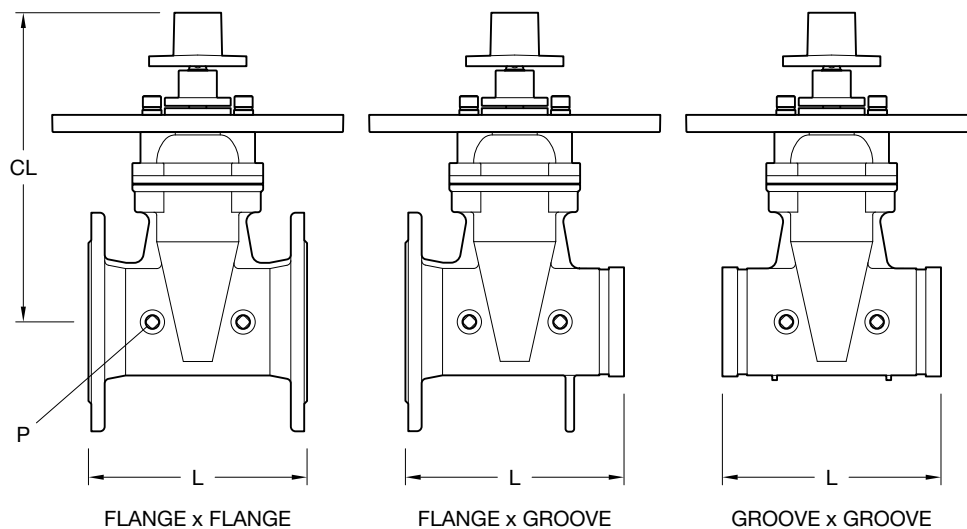
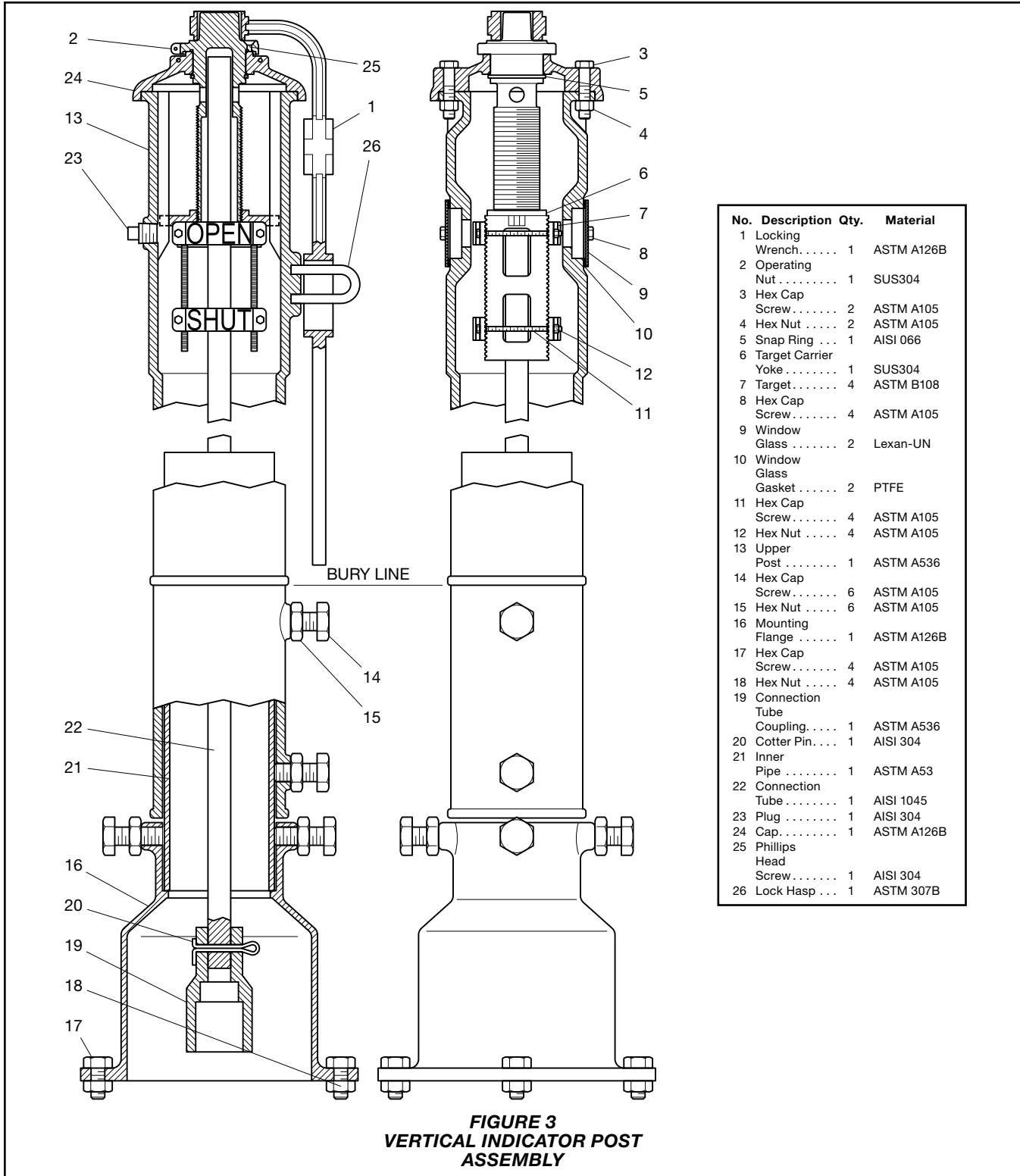
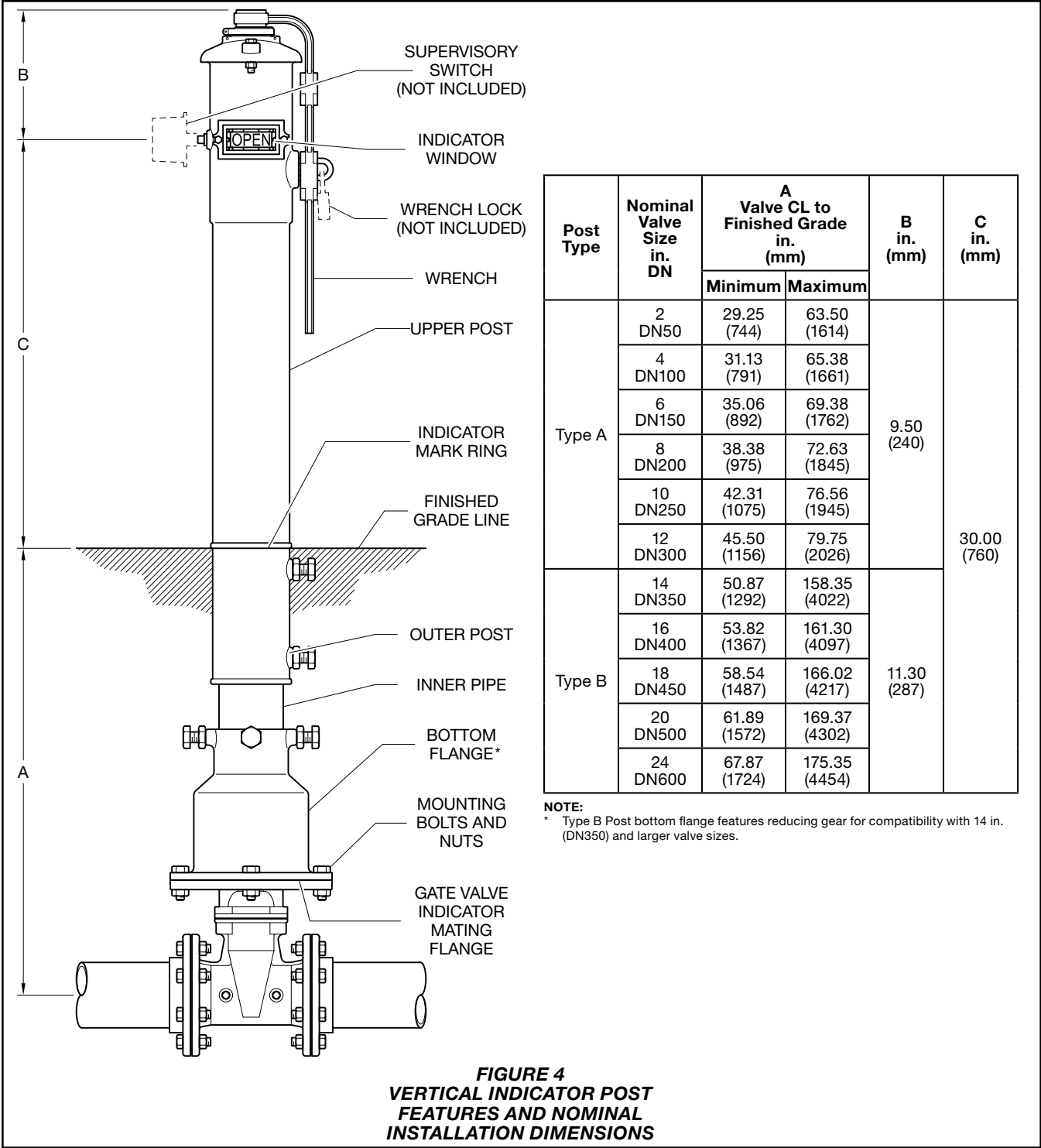

FIGURE 2
POST INDICATOR GATE VALVE
NOMINAL DIMENSIONS



No.	Description	Qty.	Material
1	Locking Wrench	1	ASTM A126B
2	Operating Nut	1	SUS304
3	Hex Cap Screw	2	ASTM A105
4	Hex Nut	2	ASTM A105
5	Snap Ring	1	AISI 066
6	Target Carrier Yoke	1	SUS304
7	Target	4	ASTM B108
8	Hex Cap Screw	4	ASTM A105
9	Window Glass	2	Lexan-UN
10	Window Glass Gasket	2	PTFE
11	Hex Cap Screw	4	ASTM A105
12	Hex Nut	4	ASTM A105
13	Upper Post	1	ASTM A536
14	Hex Cap Screw	6	ASTM A105
15	Hex Nut	6	ASTM A105
16	Mounting Flange	1	ASTM A126B
17	Hex Cap Screw	4	ASTM A105
18	Hex Nut	4	ASTM A105
19	Connection Tube Coupling	1	ASTM A536
20	Cotter Pin	1	AISI 304
21	Inner Pipe	1	ASTM A53
22	Connection Tube	1	AISI 1045
23	Plug	1	AISI 304
24	Cap	1	ASTM A126B
25	Phillips Head Screw	1	AISI 304
26	Lock Hasp	1	ASTM 307B

FIGURE 3
VERTICAL INDICATOR POST
ASSEMBLY



Installation Vertical Indicator Post, 4 in. to 12 in. (DN100 to DN300) Valves

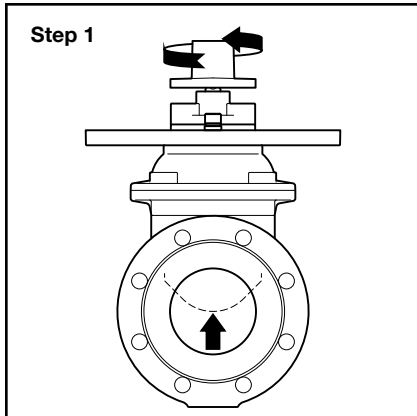

Step 1. Rotate gate valve top cap clockwise to fully open gate valve.

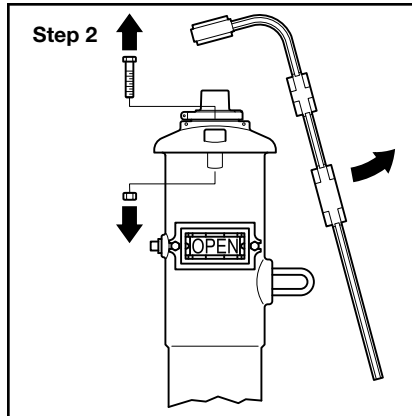

Step 2. Remove indicator wrench and cap bolts and nuts.

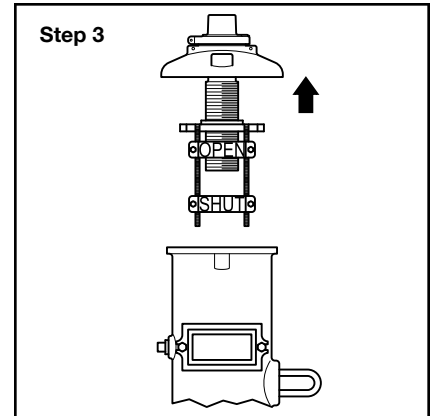

Step 3. Remove cap assembly from body cavity.

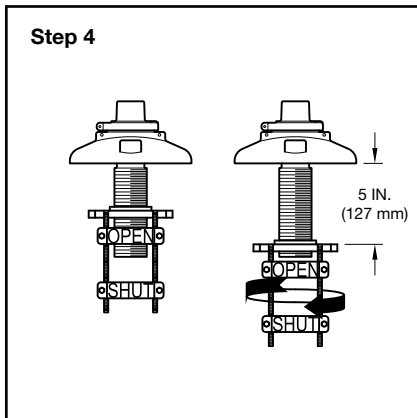

Step 4. Rotate target carrier assembly around operating nut stem to adjust distance between top surface of carrier yoke and bottom flange of cap to 5 in. (127 mm).

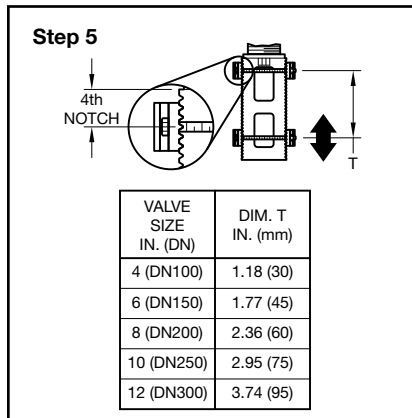

Step 5. Engage middle tooth (center-line) of OPEN target in fourth notch in serrated edge from top surface of carrier yoke. Locate SHUT target per Dimension T in table.

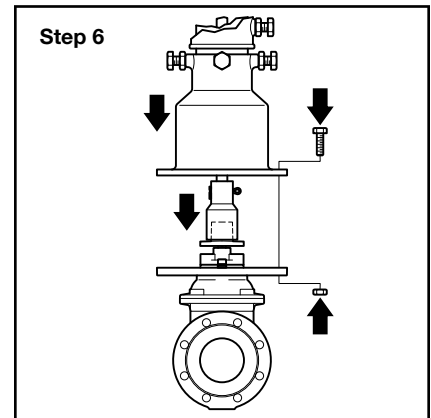

Step 6. Temporarily engage connection tube coupling onto gate valve top cap and attach indicator to gate valve mounting flange with bolts and nuts.

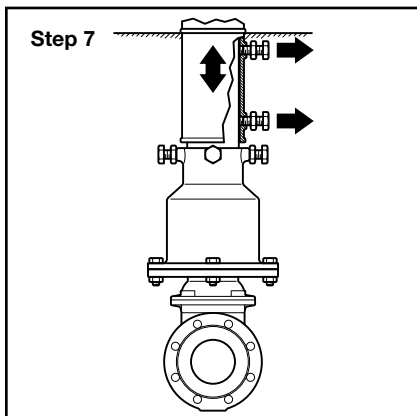

Step 7. Loosen jam nuts and bolts to free indicator outer pipe from inner pipe. Adjust outer pipe bury line even with finished grade.

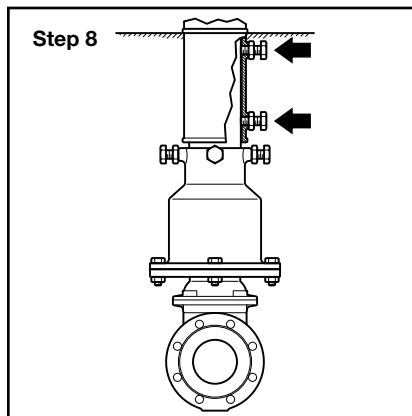

Step 8. Tighten bolts and jam nuts to secure outer pipe onto inner pipe.

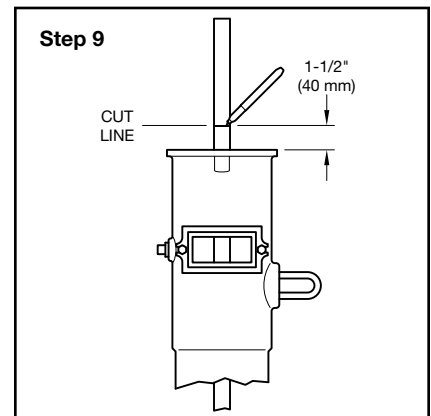

Step 9. Mark cut line on connection tube 1 1/2 in. (40 mm) above top flange of body.

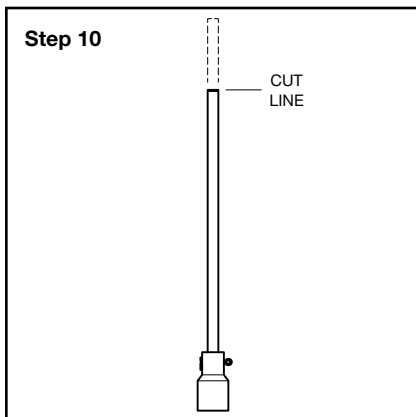

Step 10. Remove connection tube from body and cut at cut line.

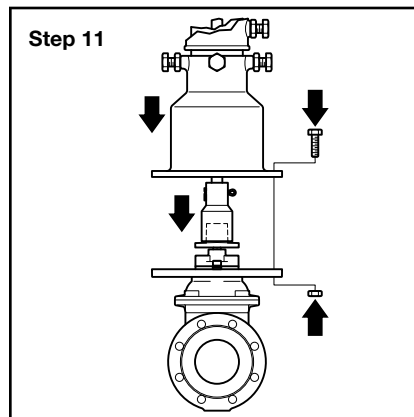

Step 11. Temporarily detach indicator from gate valve and raise to gain access to gate valve top cap. Engage connection tube coupling onto gate valve top cap.

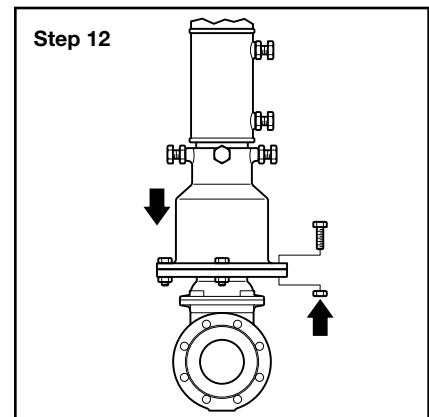

Step 12. Secure indicator to gate valve with bolts and nuts.

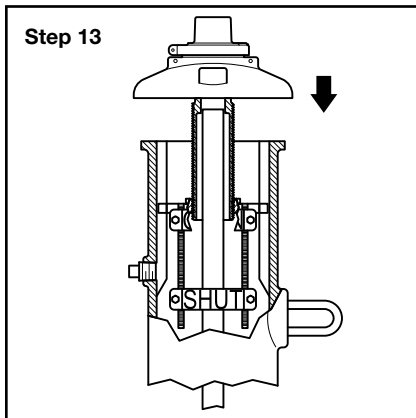

Step 13. Insert cap assembly into body cavity, aligning carrier yoke keyway slots with body keys and square hole in operating nut stem with connection tube.

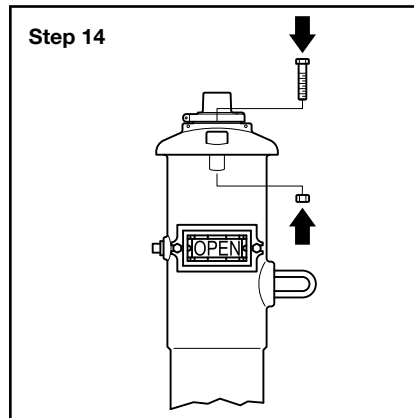

Step 14. Secure cap to body with bolts and nuts.

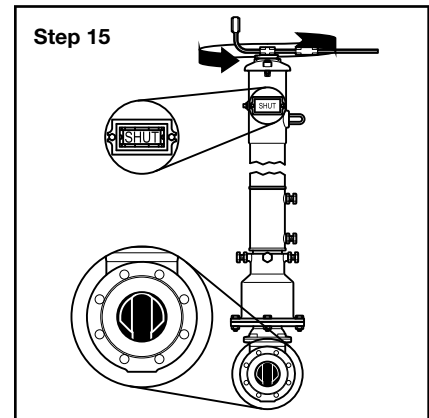

Step 15. Attach wrench to operating nut and rotate counter-clockwise. Observe gate valve waterway to verify wedge in fully SHUT position. Observe indicator to verify SHUT targets centered in windows.

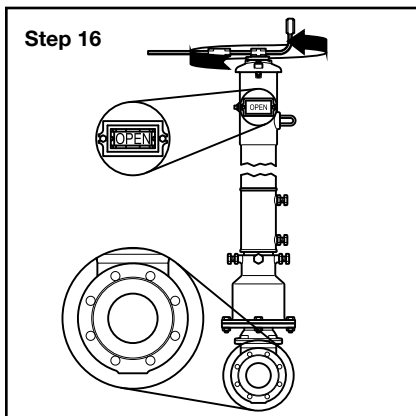

Step 16. Rotate wrench clockwise. Observe gate valve waterway to verify wedge in fully OPEN position. Observe indicator to verify OPEN targets centered in windows.

Note: Adjust position of targets on carrier yoke as necessary if conditions in Steps 15 and 16 are not achieved. Gate valve must prevent flow when indicator displays SHUT condition. Similarly, gate valve must allow full flow when indicator displays OPEN condition.

Installation Vertical Indicator Post, 14 in. to 24 in. (DN350 to DN600) Valves

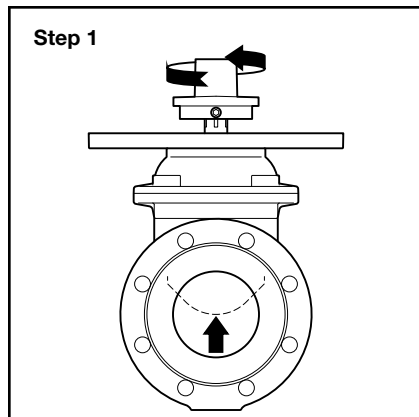

Step 1. Rotate gate valve top cap clockwise to fully open gate valve.

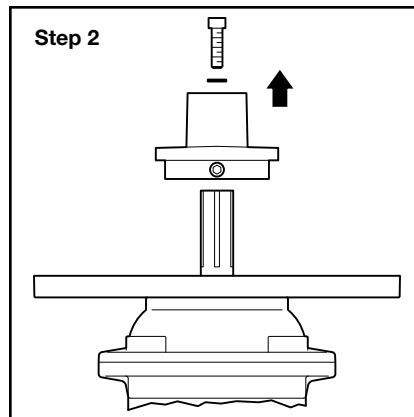

Step 2. Remove top cap from gate valve.

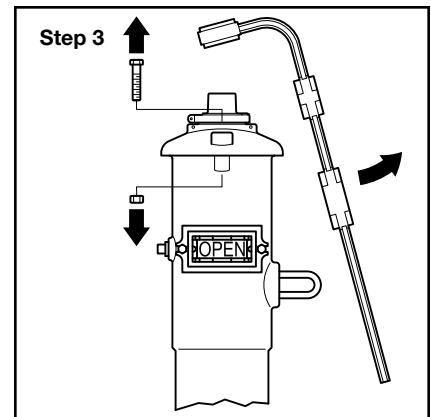

Step 3. Remove indicator wrench and cap bolts and nuts.

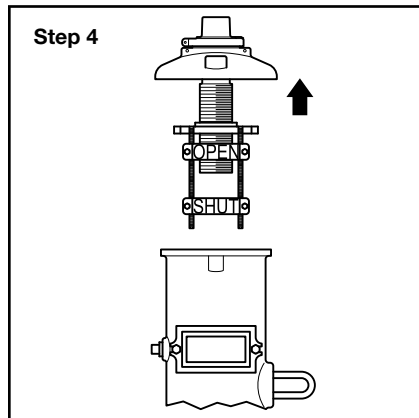

Step 4. Remove cap assembly from body cavity.

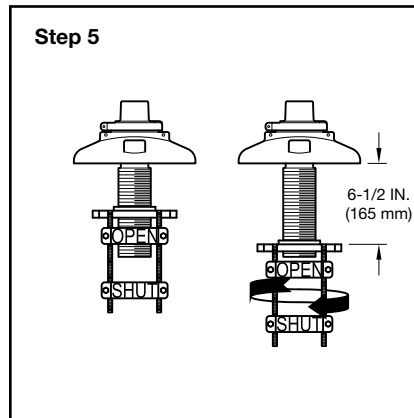

Step 5. Rotate target carrier assembly around operating nut stem to adjust distance between top surface of carrier yoke and bottom flange of cap to 6 1/2 in. (165 mm).

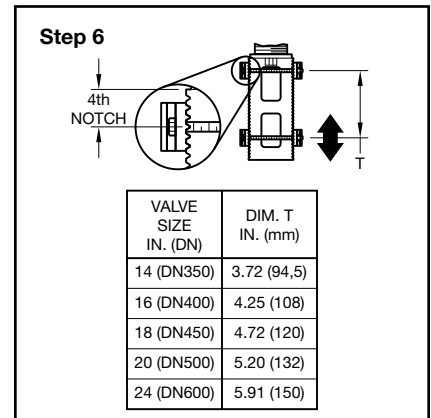

Step 6. Engage middle tooth (centerline) of OPEN target in fourth notch in serrated edge from top surface of carrier yoke. Locate SHUT target per Dimension T in table.

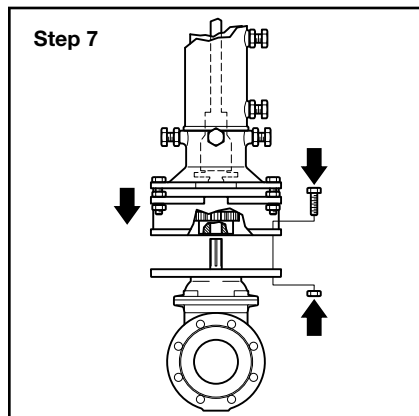

Step 7. Temporarily attach indicator to gate valve mounting flange with bolts and nuts. Ensure connection tube coupling remains engaged onto reducing gear top cap.

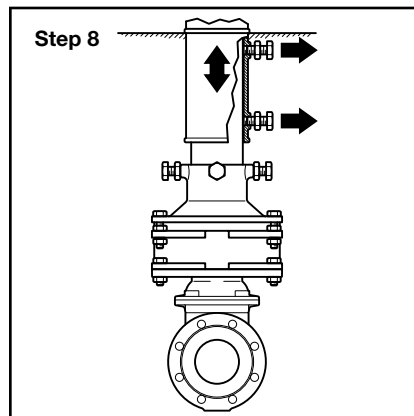

Step 8. Loosen jam nuts and bolts to free indicator outer pipe from inner pipe. Adjust outer pipe bury line even with finished grade.

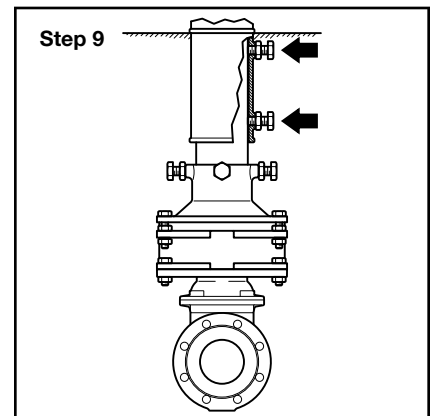

Step 9. Tighten bolts and jam nuts to secure outer pipe onto inner pipe.

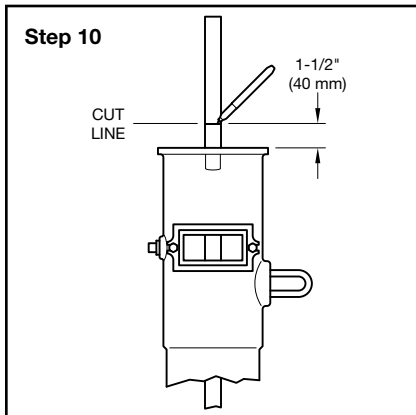

Step 10. Mark cut line on connection tube 1 1/2 in. (40 mm) above top flange of body.

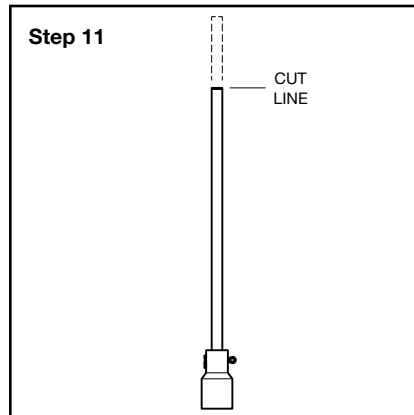

Step 11. Remove connection tube from body and cut at cut line.

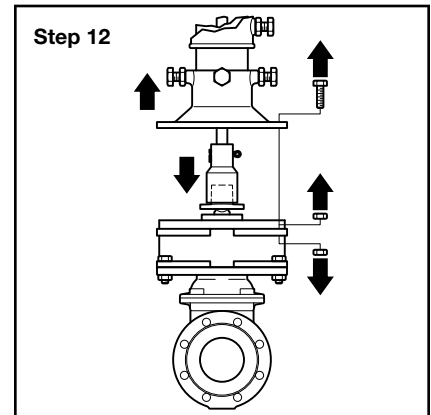

Step 12. Temporarily detach indicator from reducing gear and raise to gain access to reducing gear top cap. Engage connection tube coupling onto reducing gear top cap.

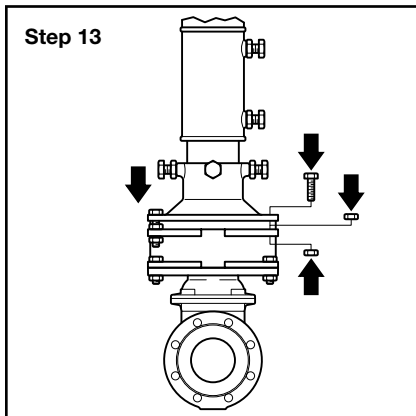

Step 13. Secure indicator to reducing gear with bolts and nuts.

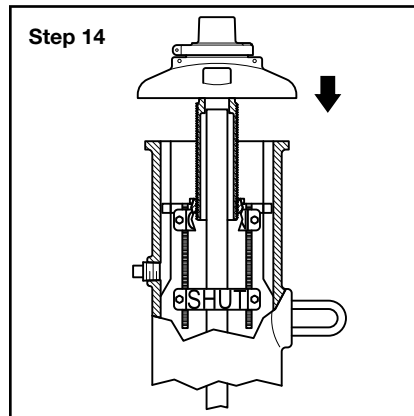

Step 14. Insert cap assembly into body cavity, aligning carrier yoke keyway slots with body keys and square hole in operating nut stem with connection tube.

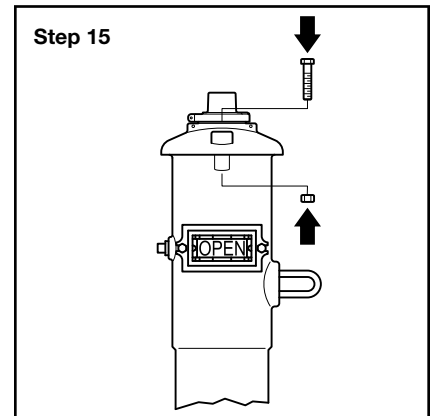

Step 15. Secure cap to body with bolts and nuts.

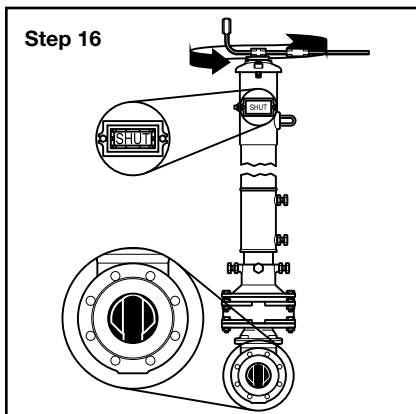

Step 16. Attach wrench to operating nut and rotate counter-clockwise. Observe gate valve waterway to verify wedge in fully SHUT position. Observe indicator to verify SHUT targets centered in windows.

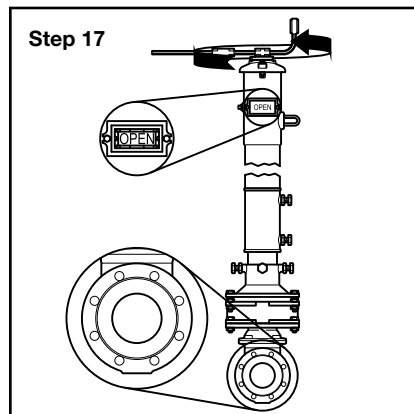

Step 17. Rotate wrench clockwise. Observe gate valve waterway to verify wedge in fully OPEN position. Observe indicator to verify OPEN targets centered in windows.

Note: Adjust position of targets on carrier yoke as necessary if conditions in Steps 16 and 17 are not achieved. Gate valve must prevent flow when indicator displays SHUT condition. Similarly, gate valve must allow full flow when indicator displays OPEN condition.

No.	Description	Qty.	Material
1	Lifting Eye Bolt	1	ASTM A307B
2	Hex Nut	1	ASTM A307B
3	Washer	1	ASTM A307B
4	Handwheel	1	ASTM A536
5	Operating Nut	1	SUS304
6	Hex Cap Screw	2	ASTM A307B
7	Hex Nut	2	ASTM A307B
8	Snap Ring	1	AISI 066
9	Target Carrier Yoke	1	SUS304

No.	Description	Qty.	Material
10	Target	4	ASTM B108
11	Hex Cap Screw	4	ASTM A307B
12	Window Glass	2	Lexan-UN
13	Window Glass Gasket	2	PTFE
14	Hex Cap Screw	4	ASTM A307B
15	Hex Nut	4	ASTM A307B
16	Body	1	ASTM A536
17	Stand Pipe	1	ASTM A53

No.	Description	Qty.	Material
18	Connection Tube	1	AISI 1045
19	Cotter Pin	1	AISI 304
20	Connection Tube Coupling	1	ASTM A536
21	Plug	1	Malleable Iron
22	Cap	1	ASTM A126B
23	Phillips Head Screw	1	AISI 304
24	Lock Hasp	1	ASTM 307B

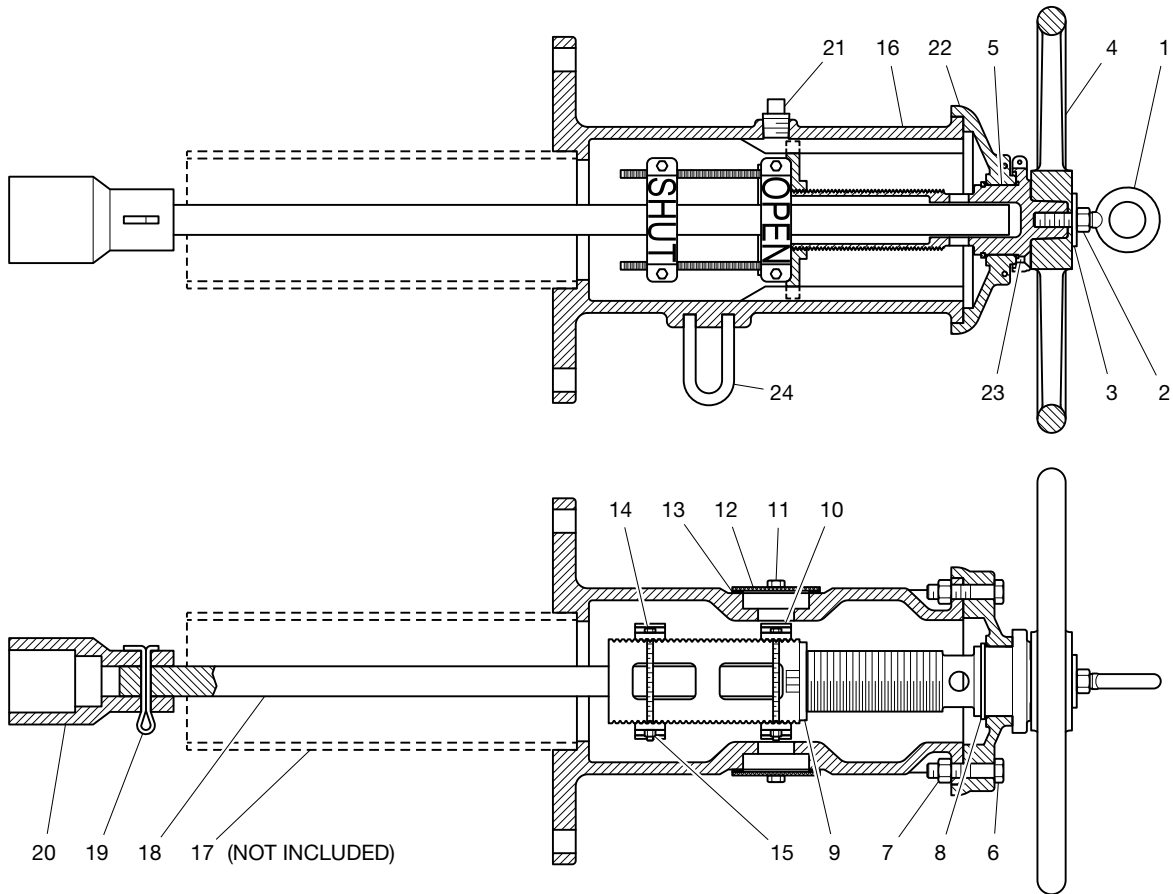

FIGURE 5
CROSS WALL INDICATOR POST
ASSEMBLY

Nominal Valve Size in. DN	A Valve CL to Exterior Wall in. (mm)		Nominal Valve Size in. DN	A Valve CL to Exterior Wall in. (mm)	
	Minimum	Maximum		Minimum	Maximum
2 DN50	10.75 (273)	98.36 (2500)	8 DN200	20.19 (513)	107.81 (2738)
4 DN100	12.75 (325)	100.36 (2550)	10 DN250	24.25 (615)	111.81 (2840)
6 DN150	16.63 (422)	104.25 (2647)	12 DN300	27.56 (700)	115.13 (2925)

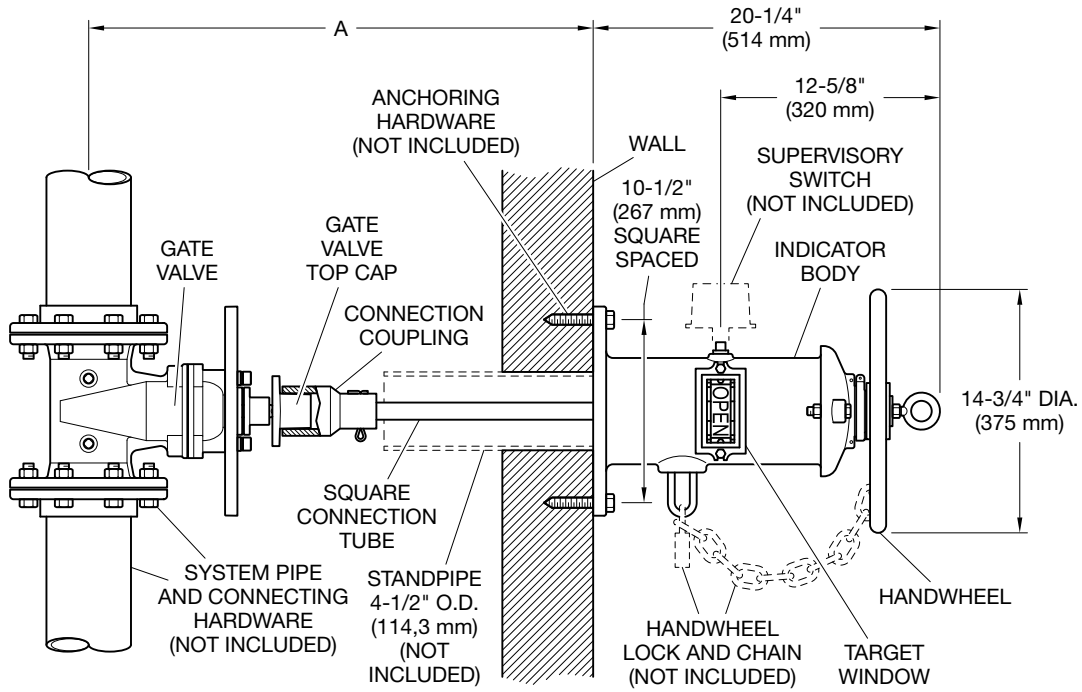
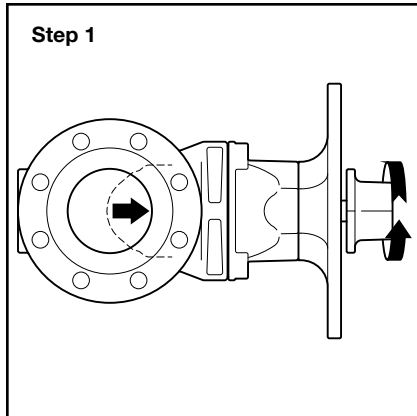
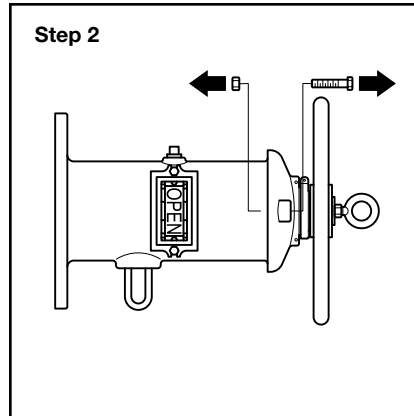

FIGURE 6
CROSS WALL INDICATOR POST
FEATURES AND NOMINAL
INSTALLATION DIMENSIONS

Installation Wall Indicator Post, 2 in. to 12 in. (DN100 to DN300) Valves



Step 1. Rotate gate valve top cap clockwise to fully open gate valve.



Step 2. Remove indicator cap bolts and nuts.

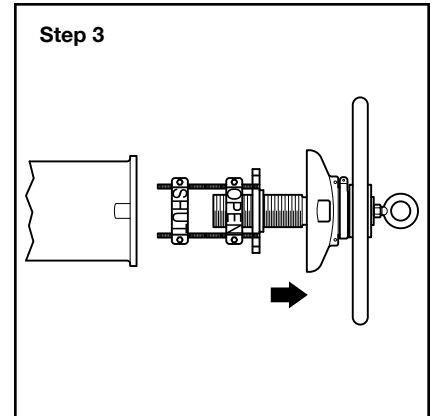

Step 3. Remove cap assembly from body cavity.

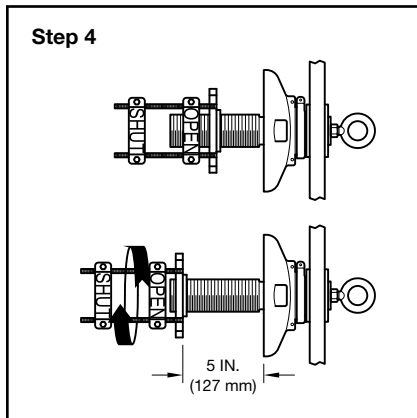

Step 4. Rotate target carrier assembly around operating nut stem to adjust distance between top surface of carrier yoke and bottom flange of cap to 5 in. (127 mm).

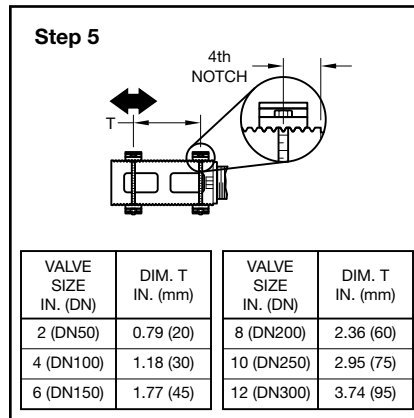

Step 5. Engage middle tooth (center-line) of OPEN target in fourth notch in serrated edge from top surface of carrier yoke. Locate SHUT target per Dimension T in table.

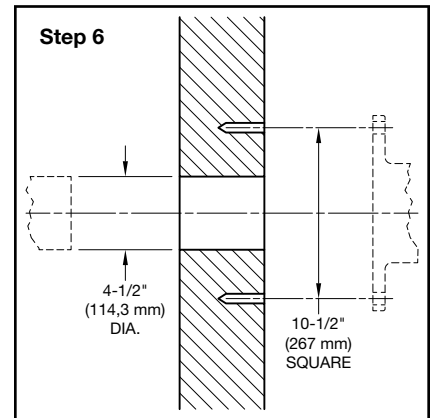

Step 6. Prepare wall for standpipe penetration and indicator mounting.

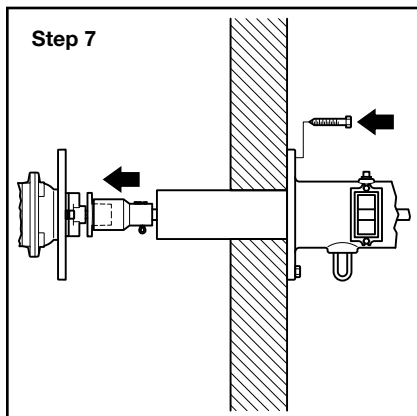

Step 7. Insert standpipe through bored hole, mount indicator body and temporarily engage connection tube coupling onto gate valve top cap.

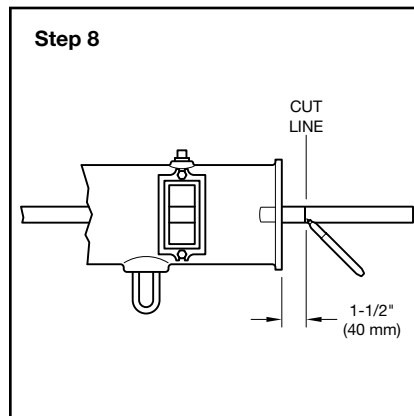

Step 8. Mark cut line on connection tube 1 1/2 in. (40 mm) beyond end flange of body.

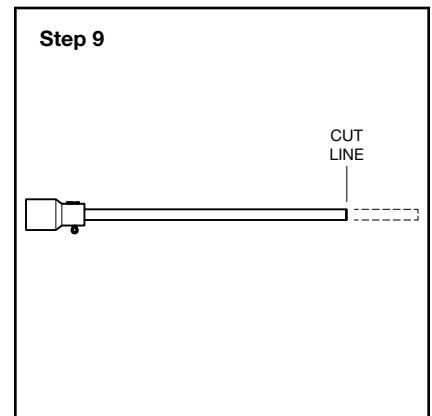

Step 9. Remove connection tube from body and cut at cut line.

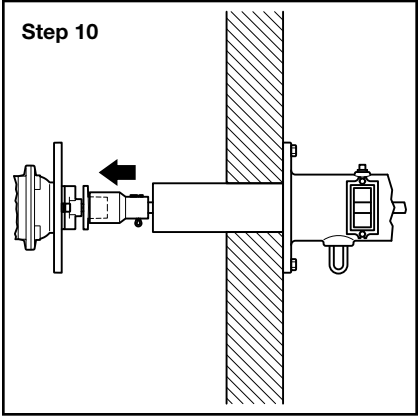

Step 10. Insert connection tube through body and standpipe and engage coupling onto gate valve top cap.

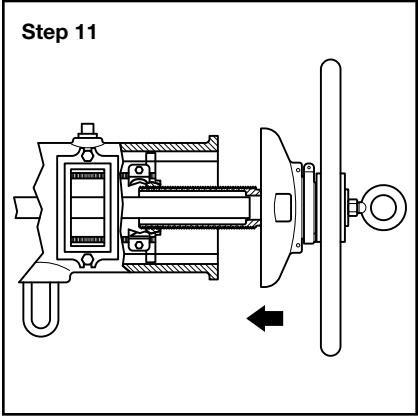

Step 11. Insert cap assembly into body cavity, aligning carrier yoke keyway slots with body keys and square hole in operating nut stem with connection tube.

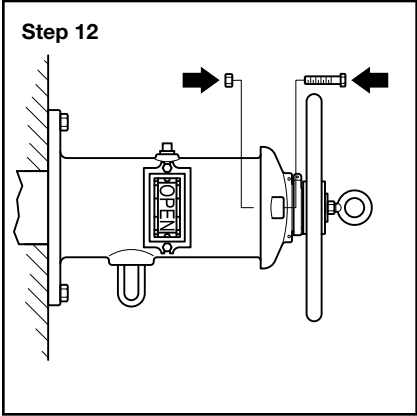

Step 12. Secure cap to body with bolts and nuts.

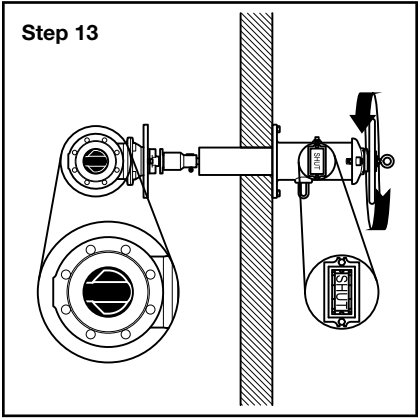

Step 13. Rotate handwheel counter-clockwise. Observe gate valve waterway to verify wedge in fully SHUT position. Observe indicator to verify SHUT targets centered in windows.

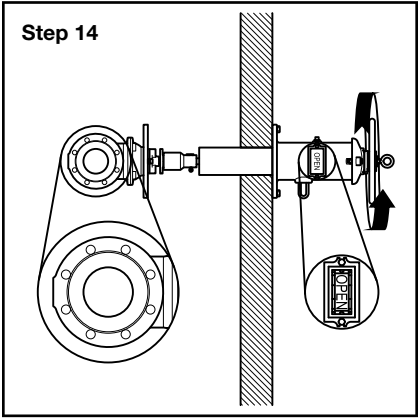

Step 14. Rotate handwheel clockwise. Observe gate valve waterway to verify wedge in fully OPEN position. Observe indicator to verify OPEN targets centered in windows.

Note: Adjust position of targets on carrier yoke as necessary if conditions in Steps 13 and 14 are not achieved. Gate valve must prevent flow when indicator displays SHUT condition. Similarly, gate valve must allow full flow when indicator displays OPEN condition.

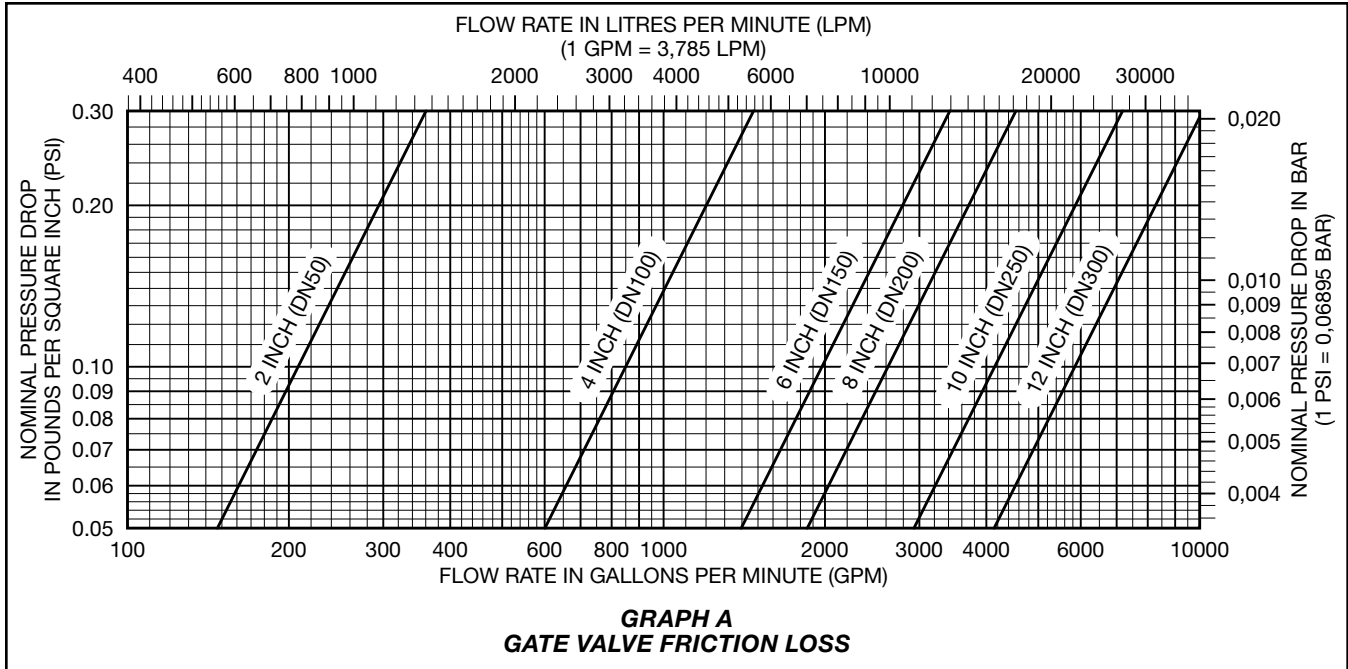

Technical Data

Sizes

2 in. to 24 in. (DN50 to DN600)

Approvals

UL and ULC Listed
 FM Approved
 Russian Fire Certificate

UL, ULC and FM Maximum Working Pressure

- 2 in. to 12 in. (DN200 to DN300):
300 psi (20,7 bar)
- 14 in. to 24 in. (DN350 to DN600):
250 psi (17,2 bar)

Flanges

ASME B16.1/ASME B16.42
 EN 1092-2/ISO 7005-2/
 Drilled to ANSI Class 150, PN16, or
 AS 2129. See Table E.

Materials of Construction

See individual valve and indicator parts lists in Figures 1, 4, and 6.

Care and Maintenance

The TYCO Resilient-Seated Gate Valves with Vertical or Cross Wall Post Indicators must be maintained and serviced in accordance with this section.

Before closing a fire protection system main control valve for maintenance work on the fire protection system that it controls, permission to shut down the affected fire protection system must be obtained for the proper authorities and notify all personnel who may be affected by this action.

After placing a fire protection system in service, notify the proper authorities and advise those responsible for monitoring proprietary and/or central station alarms.

The owner is responsible for the inspection, testing, and maintenance of their fire protection system and devices in compliance with this document, as well as with the applicable standards of the NFPA, for example, NFPA 25, in addition to the standards of any authorities having jurisdiction. Contact the installing contractor or sprinkler manufacturer regarding any questions.

Automatic sprinkler systems are recommended to be inspected, tested, and maintained by a qualified inspection service in accordance with local requirements and/or national codes.

Gate Valve

Debris lodged in the sealing area of the wedge may cause the valve to close hard. Backing off the indicator wrench or handwheel and closing it again, several times if necessary, can correct this problem.

The valve should never be forced to seat by applying a wrench or extension to the lever, as it may distort the valve components or score the sealing surfaces. All replacement parts must be obtained from the manufacturer to assure proper operation of the valve.

Vertical Indicator Post

It is recommended that Vertical Indicator Posts used to operate fire protection system water control valves be locked in the fully open position using the wrench. The locks must be sturdy and resistant to breakage except by heavy bolt cutters.

It is recommended that a visual inspection be carried out on a monthly basis to ensure:

- the Post Cap, Upper Barrel, and windows have not been damaged
- the Targets indicate that the valve is open
- the Wrench is in place on the Post and is securely locked

It is further recommended that on a quarterly basis, the Vertical Indicator Post should be closed two turns and then reopened to verify that the PIV is in the fully open position and properly engages with the Post. Where a Supervisory Switch is installed, a check should be undertaken to ensure that the contacts are working properly.

Any missing or damaged parts should be immediately replaced.

Note: If the target carrier yoke must be disassembled or cleaned for any reason, apply LOCTITE LB8150 or an equivalent grease as a lubricant to the stainless-steel threads of the operating nut prior to reassembly.

Nominal Valve Size	Nominal Pipe Size	Part Number					
		Flange x Flange ANSI Class 150	Flange x Flange ISO 7005-2 PN16	Flange x Groove ANSI Class 150	Flange x Groove ISO 7005-2 PN16	Flange x Flange AS 2129 (Table E)	Groove x Groove
2 DN50	2.375 (60.3)	TJPX0500003	TJPX0500001	TJPT0500603	TJPT0500601	TJPX0500005	TJPG0500604
4 DN100	4.500 (114.3)	TJPX1000003	TJPX1000001	TJPT1001143	TJPT1001141	TJPX1000005	TJPG1001144
6 DN150	6.625 (168.3)	TJPX1500003	TJPX1500001	TJPT1501683	TJPT1501681	TJPX1500005	TJPG1501684
8 DN200	8.625 (219.1)	TJPX2000003	TJPX2000001	TJPT2002193	TJPT2002191	TJPX2000005	TJPG2002194
10 DN250	10.750 (273.1)	TJPX2500003	TJPX2500001	TJPT2502733	TJPT2502731	TJPX2500005	TJPG2502734
12 DN300	12.750 (323.9)	TJPX3000003	TJPX3000001	TJPT3003243	TJPT3003241	TJPX3000005	TJPG3003244
14 DN350	14.0 (355.6)	TJPX3500003	TJPX3500001	—	—	TJPX3500005	—
16 DN400	16.0 (406.4)	TJPX4000003	TJPX4000001	—	—	TJPX4000005	—
18 DN450	18.0 (457.2)	TJPX4500003	TJPX4500001	—	—	TJPX4500005	—
20 DN500	20.0 (508.0)	TJPX5000003	TJPX5000001	—	—	TJPX5000005	—
24 DN600	24.0 (609.6)	TJPX6000003	TJPX6000001	—	—	TJPX6000005	—

**TABLE B
POST INDICATOR GATE VALVE
PART NUMBERS**

Cross Wall Indicator Post

It is recommended that Cross Wall Indicator Posts used to operate fire protection system water control valves be locked in the fully open position using the Handwheel. The locks must be sturdy and resistant to breakage except by heavy bolt cutters.

It is recommended that a visual inspection be carried out on a monthly basis to ensure:

- the Post body, Handwheel, and windows have not been damaged
- the Targets indicate that the valve is open
- the Post is properly locked open

It is further recommended that on a quarterly basis, the Cross Wall Indicator Post should be closed two turns and then reopened to verify that the PIV is in the fully open position and properly engages with the Post and that the Supervisory Switch contacts are working properly.

Any damaged parts should be immediately replaced.

Note: If the target carrier yoke must be disassembled or cleaned for any reason, apply **LOCTITE LB8150** or an equivalent grease as a lubricant to the stainless-steel threads of the operating nut prior to reassembly.

**Limited
Warranty**

For warranty terms and conditions, visit www.tyco-fire.com.

**Ordering
Procedure**

Contact your local distributor for availability. When placing an order, indicate the full product name and Part Number (P/N).

Refer to Table B for Gate Valve part numbers and Table C for Vertical and Cross Wall Indicator Post part numbers.

**Replacement Vertical
Indicator Post Wrench**

All Vertical Indicator Post types feature a removable wrench for operating the PIV. Replace as necessary.

Specify: Vertical Indicator Post Wrench, P/N TJUPWRENCH

Indicator Post	Part Number
Vertical Type A	TJUPA
Vertical Type B	TJUPB
Cross Wall	TJWP

**TABLE C
VERTICAL AND CROSS WALL
INDICATOR POST
PART NUMBERS**

