

Resilient-Seated Gate Valves Outside Screw and Yoke

General Description

TYCO Resilient-Seated Gate Valves are used in Fire Protection Systems for on/off operation. End connection configurations including Flange x Flange, Flange x Groove, and Groove x Groove are available. All of the end connection configurations have tapping bosses.

The ductile Iron body weighs approximately 50% less than conventional cast iron valves, which allows easier handling on site and reduced shipping costs.

The fully encapsulated EPDM ductile iron Wedge ensures bubble-tight sealing.

Valve components are either inherently corrosion-resistant or protected with fusion-bonded epoxy resin coating for a long, dependable service life and enhanced UV protection in exposed installations.

This valve is one of the lightest, most durable gate valves on the market today. Its design features and material selection criteria fulfill the need for a dependable, long life and easy to operate gate valve.

NOTICE

Never remove any piping component nor correct or modify any piping deficiencies without first de-pressurizing and draining the system. Failure to do so may result in serious personal injury, property damage, and/or impaired device performance.

It is the designer's responsibility to select products suitable for the intended service and to ensure that pressure ratings and performance data are not exceeded. Material and gasket selection should be verified for com-

patibility with the specific application. Always read and understand the installation instructions.

TYCO Gate Valves described herein must be installed and maintained in compliance with this document, in addition to the standards of any other authorities having jurisdiction. Failure to do so may result in serious personal injury or impair the performance of these devices.

The owner is responsible for maintaining their mechanical system and devices in proper operating condition. The installing contractor or device manufacturer should be contacted with any questions.

Technical Data

Sizes

2 in. to 16 in. (DN50 to DN400)

Approvals

UL and ULC Listed
FM Approved
Russian Fire Certificate

Maximum Working Pressure

- 2 in. to 12 in. (DN50 to DN300):
300 psi (20,7 bar)
- 14 in. (DN350) and 16 in. (DN400):
250 psi (17,2 bar)

End Connections

Flange x Flange, Flange x Groove or Groove x Groove
(See Table A for size applicability)

Flanges

ASME B16.1/ASME B16.42
EN 1092-2/ISO 7005-2
Drilled to ANSI 150 or PN10/PN16 or AS 2129 (Table E)

Materials of Construction

See Figure 1

Tapping Bosses

Two factory-plugged NPT threaded tapping bosses are located on the up- and downstream sides of the wedge for connection to valve trim. Tapping boss NPT Inch sizes:

2 in. to 6 in. (DN50 to DN150) 1/2
8 in. (DN200) 3/4
10 in. to 16 in. (DN250 to DN400) 1

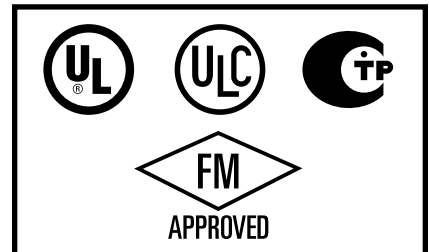

Installation

In piping systems, TYCO Resilient-Seated Gate Valves should be located where operation, inspection, and maintenance are readily accessible.

IMPORTANT

Refer to Technical Data Sheet TFP2300 for warnings pertaining to regulatory and health information.

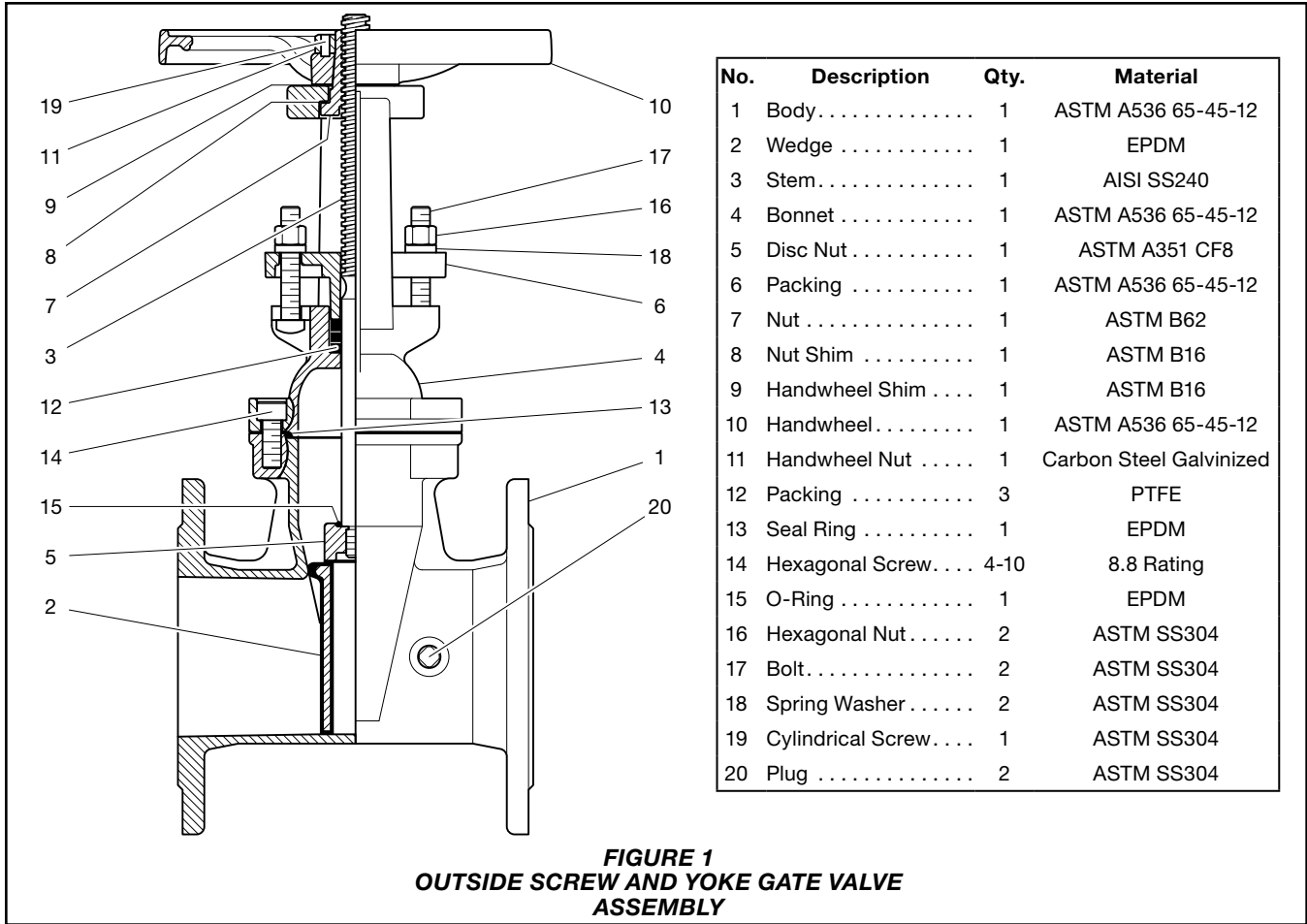

Care and Maintenance

The TYCO Resilient-Seated Gate Valves must be maintained and serviced in accordance with this section.

Before closing a fire protection system main control valve for maintenance work on the fire protection system that it controls, obtain permission to shut down the affected fire protection system from the proper authorities and notify all personnel who may be affected by this decision.

After placing a fire protection system in service, notify the proper authorities and advise those responsible for monitoring proprietary and/or central station alarms.

The owner is responsible for the inspection, testing, and maintenance of their fire protection system and devices in compliance with this document, as well as with the applicable standards of the

NATIONAL FIRE PROTECTION ASSOCIATION, such as NFPA 25, in addition to the standards of any authority having jurisdiction. The installing contractor or product manufacturer should be contacted relative to any questions. Any impairments must be immediately corrected.

Automatic sprinkler systems are recommended to be inspected, tested, and maintained by a qualified Inspection Service in accordance with local requirements and/or national codes.

See Figure 1 for valve components referenced in this section.

Debris lodged in the sealing area of the Wedge (2) may cause the valve to close hard. Backing off the Handwheel (10) and closing it again, several times if necessary, can correct this problem.

The valve should never be forced to seat by applying a wrench or extension to the Handwheel (10), as it may distort the valve components or score the sealing surfaces. All replacement

parts must be obtained from the manufacturer to assure proper operation of the valve.

At initial valve installation the Hexagonal Nuts (16) should be left only finger tight to allow the Packing (12) to remain in a relaxed state during normal valve operation. For applications where the valve is subject to vibration, a non-hardening thread sealant may be applied to the Hexagonal Nuts (16) to prevent self-loosening and subsequent disengagement of the Packing (12).

If leakage past the O-Ring (15) occurs, evenly tighten the Hexagonal Nuts (16) until the leakage ceases.

Nominal Valve Size	Nominal Pipe Size	Nominal Dimensions in. (mm)			P Tapping Boss Size ANSI in. NPT	Nominal Handwheel Turns to Fully Operate (Open or Shut)	Approx. Weight F x F lb (kg)	Approx. Weight F x G lb (kg)	Approx. Weight G x G lb (kg)
		L	CL1	CL2					
2 DN50	2.375 (60.3)	7.00 (178)	15.55 (395)	13.07 (332)	1/2	13	38.8 (17.64)	36.7 (16.7)	34.7 (15.8)
2 1/2 DN65	2.875 (73.0)	7.50 (190)	16.14 (410)	13.31 (338)		16	41.6 (18.91)	39.1 (17.8)	36.5 (16.6)
– DN65	3.000 (76.1)	7.50 (190)	16.14 (410)	13.31 (338)		16	41.6 (18.91)	39.1 (17.8)	36.5 (16.6)
3 DN80	3.500 (88.9)	8.00 (203)	18.9 (480)	14.96 (380)		20	48.7 (22.13)	48.3 (22.0)	48.0 (21.8)
4 DN100	4.500 (114.3)	9.00 (229)	22.56 (573)	17.72 (450)		20	59.8 (27.16)	56.3 (25.6)	52.8 (24.0)
– DN150	6.500 (165.1)	10.00 (254)	29.53 (750)	23.31 (592)		25	103.2 (46.9)	98.9 (45.0)	94.6 (43.0)
6 DN150	6.625 (168.3)	10.50 (267)	29.53 (750)	23.31 (592)		25	103.2 (46.9)	98.9 (45.0)	94.6 (43.0)
8 DN200	8.625 (219.1)	11.50 (292)	37.64 (956)	29.45 (748)	3/4	34	158.4 (72.0)	160.6 (73.0)	162.8 (74.0)
10 DN250	10.750 (273.1)	13.00 (330)	46.26 (1175)	34.96 (888)	1	42	244.2 (111.0)	238.7 (108.5)	233.2 (106.0)
12 DN300	12.750 (323.9)	14.00 (356)	51.89 (1318)	39.57 (1005)		50	367.4 (167.0)	359.7 (163.5)	352.0 (160.0)
14 DN350	14.014 (355.6)	15.00 (381)	47.44 (1205)	62.09 (1577)		20	631.4 (287.0)	–	–
16 DN400	16.000 (406.4)	15.98 (406)	54.45 (1383)	70.87 (1800)		20	827.2 (376)	–	–

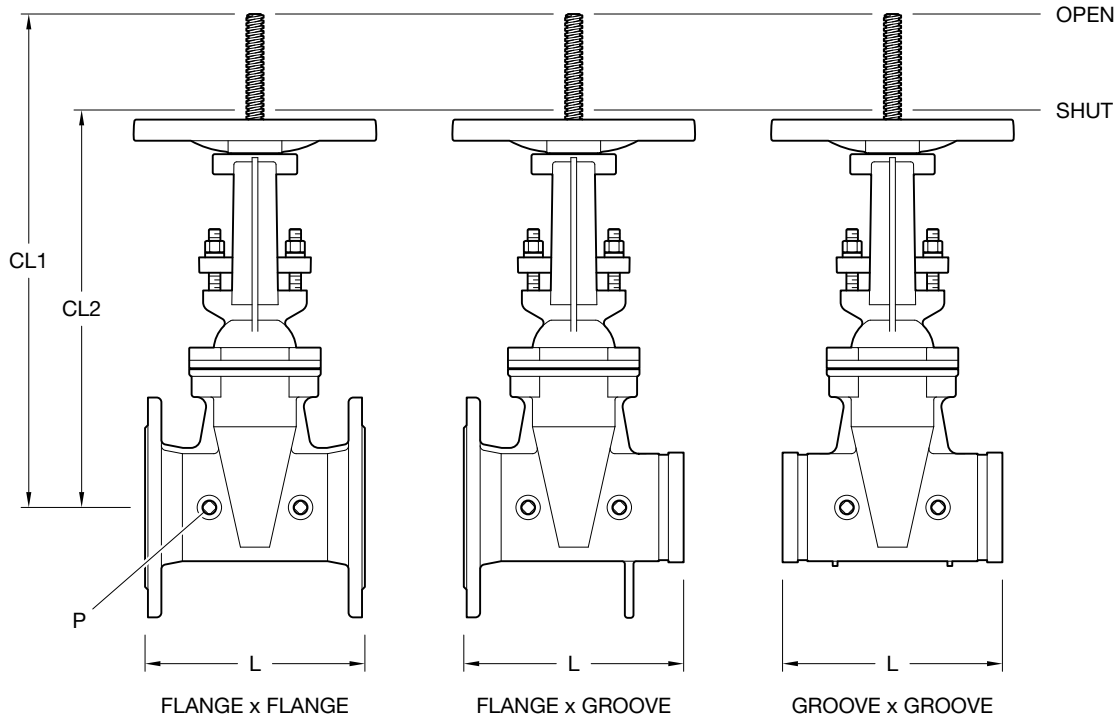

FIGURE 2
OUTSIDE SCREW AND YOKE GATE VALVE DN50 TO DN300
NOMINAL DIMENSIONS

Nominal Valve Size	Nominal Dimensions in In. (mm)								
	ANSI Class 150			ISO 7005-2 PN16			AS 2129 (Table E)		
	Dim. A	Dim. B	Qty. N	Dim. A	Dim. B	Qty. N	Dim. A	Dim. B	Qty. N
2 DN50	4.75 (120.5)	0.75 (19)	4	4.92 (125.0)	0.75 (19)	4	4.48 (114.0)	0.71 (18.0)	4
2 1/2 DN65	5.50 (139.5)	0.75 (19)	4	5.71 (145.0)	0.75 (19)	4	5.00 (127.0)	0.71 (18.0)	4
3 DN80	6.00 (152.5)	0.75 (19)	4	6.30 (160.0)	0.75 (19)	8	5.74 (146.0)	0.71 (18.0)	4
4 DN100	7.50 (190.5)	0.75 (19)	8	7.09 (180.0)	0.75 (19)	8	7.00 (178.0)	0.71 (18.0)	8
6 DN150	9.50 (241.5)	0.88 (22)	8	9.45 (240.0)	0.88 (23)	8	9.25 (235.0)	0.87 (22.0)	8
8 DN200	11.75 (298.5)	0.88 (22)	8	11.61 (295.0)	0.88 (23)	12	11.49 (292.0)	0.87 (22.0)	8
10 DN250	14.25 (362.0)	1.00 (25)	12	13.98 (355.0)	1.13 (28)	12	14.02 (356.0)	0.87 (22.0)	12
12 DN300	17.00 (432.0)	1.00 (25)	12	16.14 (410.0)	1.13 (28)	12	15.98 (406.0)	1.02 (26.0)	12
14 DN350	18.75 (476.3)	1.13 (28.6)	12	18.5 (470.0)	1.102 (28)	16	19.49 (495.0)	1.22 (31.0)	16
16 DN400	21.25 (539.8)	1.13 (28.6)	16	20.7 (525.0)	1.22 (31)	16	21.73 (552.0)	1.22 (31.0)	16

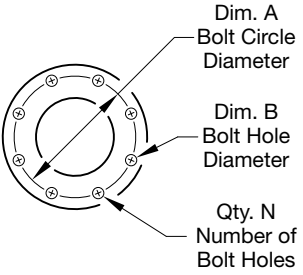
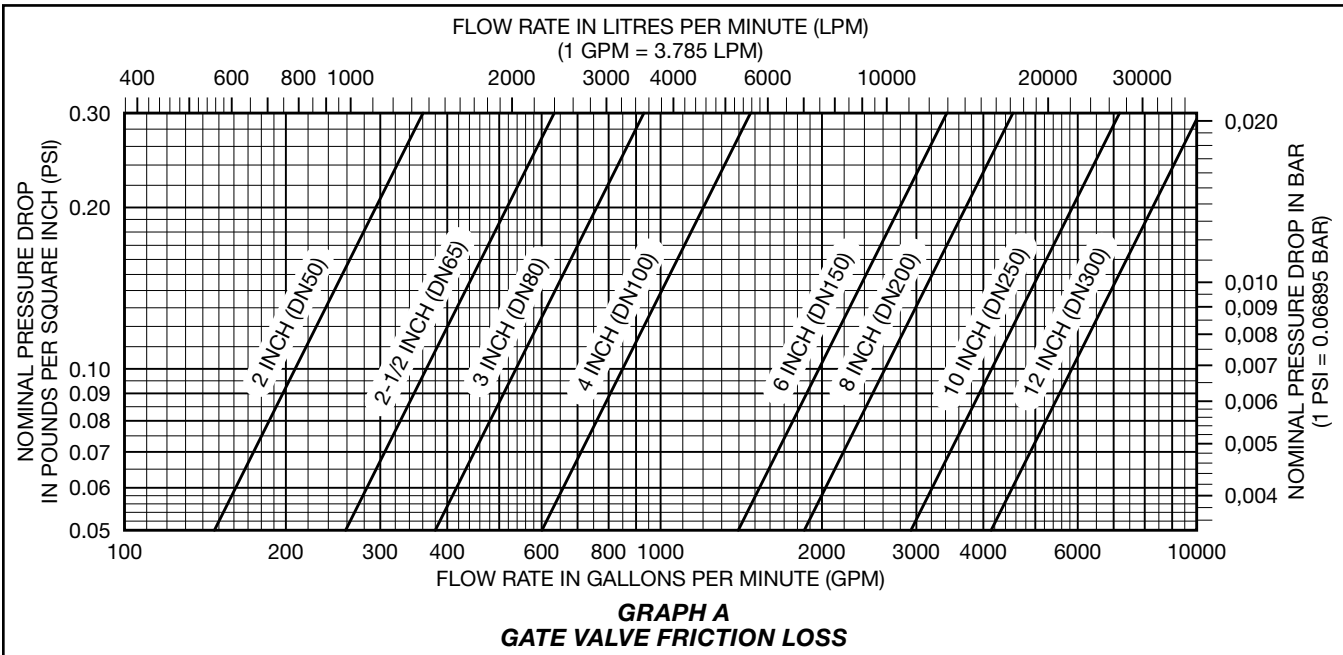

FIGURE 3
GATE VALVE FLANGE
NOMINAL DIMENSIONS



Nominal Valve Size	Nominal Pipe Size	Part Number					
		Flange x Flange ANSI Class 150	Flange x Flange ISO 7005-2 PN16	Flange x Groove ANSI Class 150	Flange x Groove ISO 7005-2 PN16	Flange x Flange AS 2129 (Table E)	Groove x Groove
2 DN50	2.375 (60.3)	TJRX0500003	TJRX0500001	TJRT0500603	TJRT0500601	TJRX0500005	TJRG0500604
2 1/2 DN65	2.875 (73.0)	TJRX0650003	TJRX0650001	TJRT0650733	TJRT0650731	TJRX0650005	TJRG0650734
– DN65	3.000 (76.1)	–	–	TJRT0650763	TJRT0650761	–	TJRG0650764
3 DN80	3.500 (88.9)	TJRX0800003	TJRX0800001	TJRT0800893	TJRT0800891	TJRX0800005	TJRG0800894
4 DN100	4.500 (114.3)	TJRX1000003	TJRX1000001	TJRT1001143	TJRT1001141	TJRX1000005	TJRG1001144
– DN150	6.500 (165.1)	–	–	TJRT1501653	TJRT1501651	–	TJRG1501654
6 DN150	6.625 (168.3)	TJRX1500003	TJRX1500001	TJRT1501683	TJRT1501681	TJRX1500005	TJRG1501684
8 DN200	8.625 (219.1)	TJRX2000003	TJRX2000001	TJRT2002193	TJRT2002191	TJRX2000005	TJRG2002194
10 DN250	10.750 (273.1)	TJRX2500003	TJRX2500001	TJRT2502733	TJRT2502731	TJRX2500005	TJRG2502734
12 DN300	12.750 (323.9)	TJRX3000003	TJRX3000001	TJRT3003243	TJRT3003241	TJRX3000005	TJRG3003244
14 DN350	14.0 (355.6)	TJRX3500003	TJRX3500001	–	–	TJRX3500005	–
16 DN400	16.0 (406.4)	TJRX4000003	TJRX4000001	–	–	TJRX4000005	–

TABLE A
OUTSIDE SCREW AND YOKE GATE VALVE
PART NUMBERS

Limited Warranty

For warranty terms and conditions, visit www.tyco-fire.com.

Ordering Procedure

Contact your local distributor for availability. When placing an order, indicate the full product name and Part Number (P/N). See Table A for a complete list of part numbers.

